

EXL015
LED Exit & Emergency Light

Catalog #		Prepared by	LiteHarbor
Project		Date	
Notes			



Exit Sign



Running Man

Description

- 1) Cold-rolled steel material or heavy duty 20 gauge steel or aluminum housing
- 2) Supplied standard with two pictogram films per face, for direction selection
- 3) AC-Only or self-powered models.
- 4) 120V/347V AC operation.
- 5) Long-life, energy-saving LED technology.
- 6) Canopy mounting system designed specifically for ease of installation.
- 7) Universal knockout chevrons.

Housing Finish

WH / BK / Brushed Aluminum

Mounting

Universal (wall, side or ceiling mounting)
 Key hole slots are stamped into the backplate

Electrical

Dual voltage input 120-347 VAC, 60 Hz
 LED Light Source

Order Matrix:

<u>A</u>	<u>B</u>	<u>C</u>	<u>D</u>	<u>E</u>	<u>F</u>	<u>G</u>
Item No.: EXL015						

A	Series
EXL015	Exit Light
B	Sign
	Exit Sign
R	Running
C	Input Voltage
	120V
347	347V
D	Face Q'ty
SF	Single Face
DF	Double Face
E	Battery Backup
	Battery Backup
AC	AC Only

EXIT & EMERGENCY LIGHT



Battery

The sign is designed with a maintenance free Self-Powered model delivers 90 minutes min. of back-up lighting

Recharge time of the battery is twenty-four (24) hours.

Warranty

EXIT: 2-Year Limited Warranty

Battery: 15 Year Pro-rata

F	Letter Color
RD	Red
GN	Green
G	Arrow Direction
	No indicators
LA	Left indicator
RA	Right indicator
UA	Up indicator
DA	Down indicator
URA	45° up right
DRA	45° down right
ULA	45° up left
DLA	45° down left

Dimensions

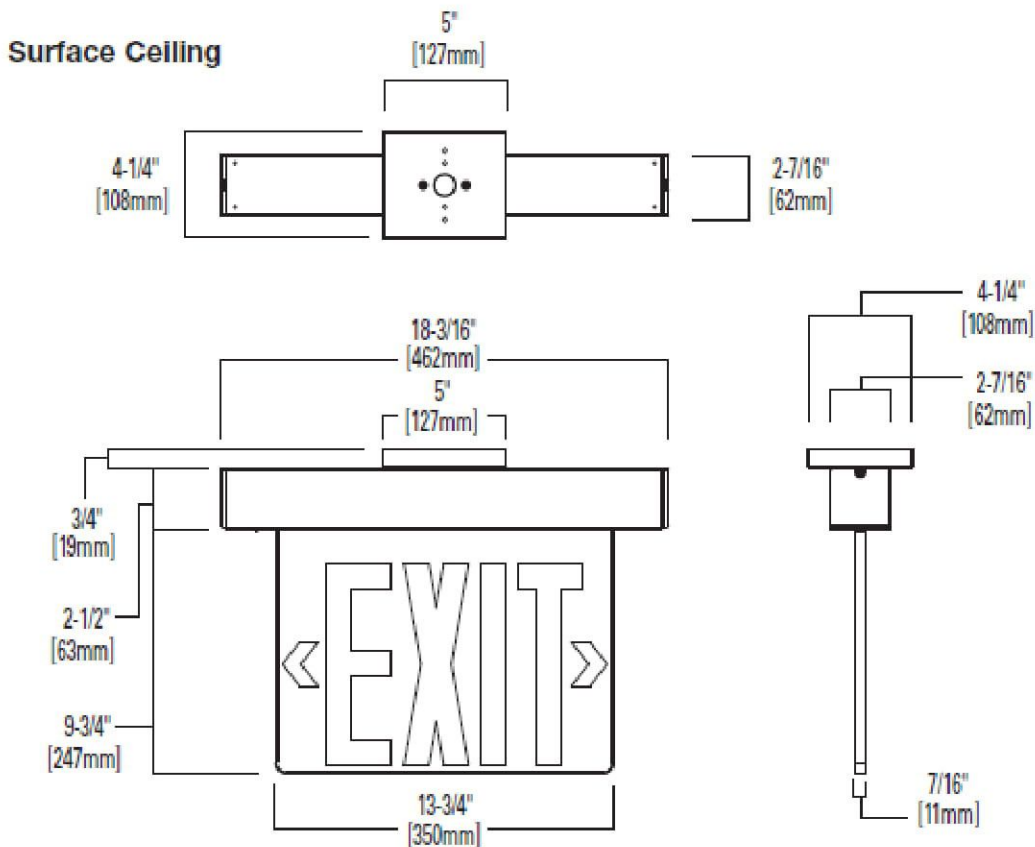

EXIT & EMERGENCY LIGHT



Surface Wall

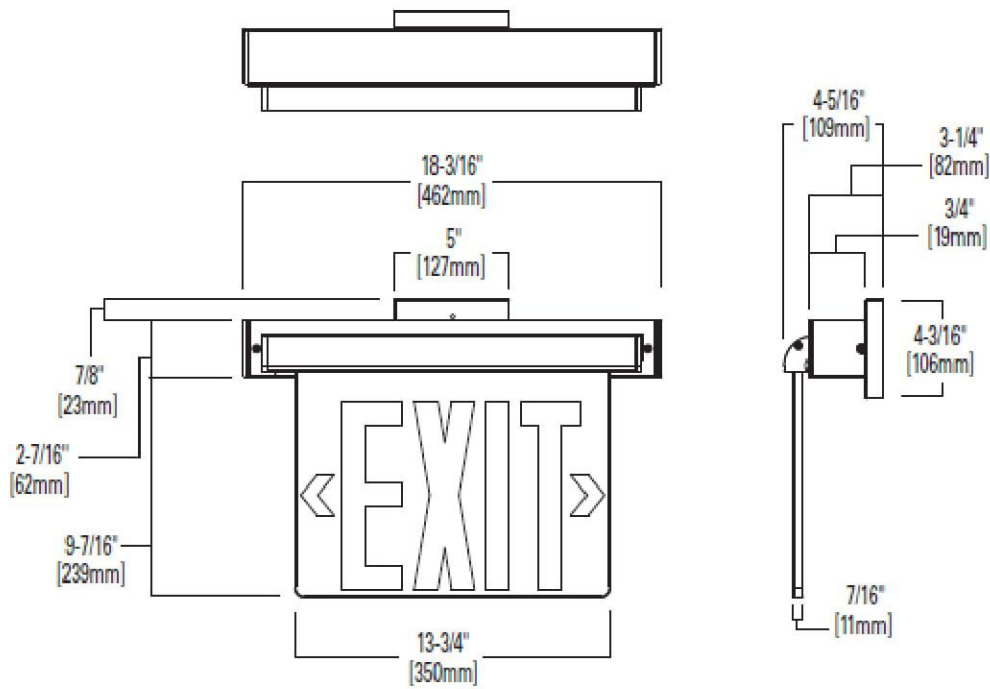

End

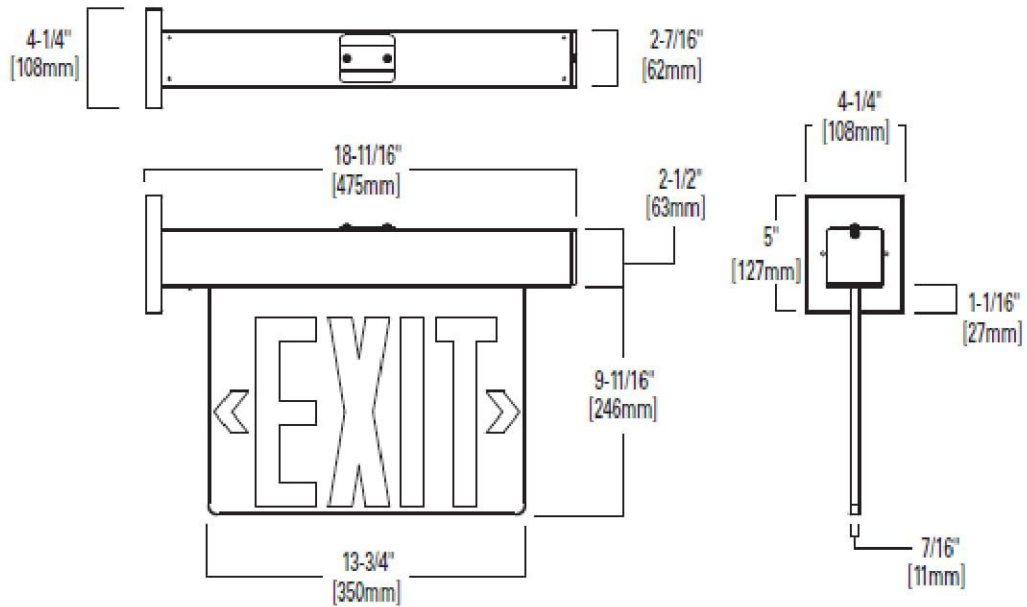

EXIT & EMERGENCY LIGHT

Ceiling

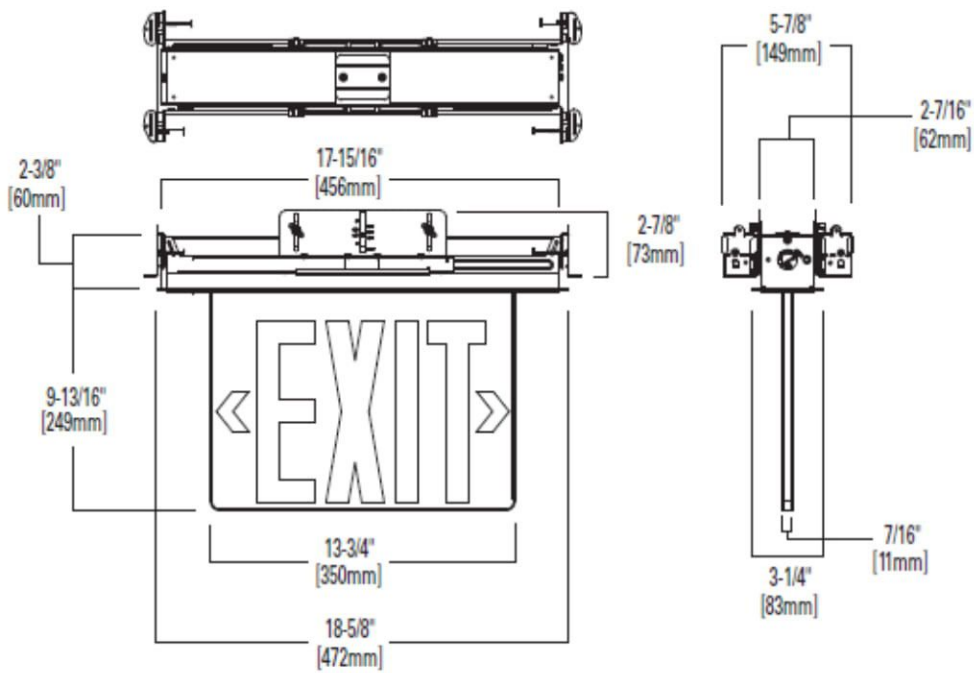

Recessed Wall

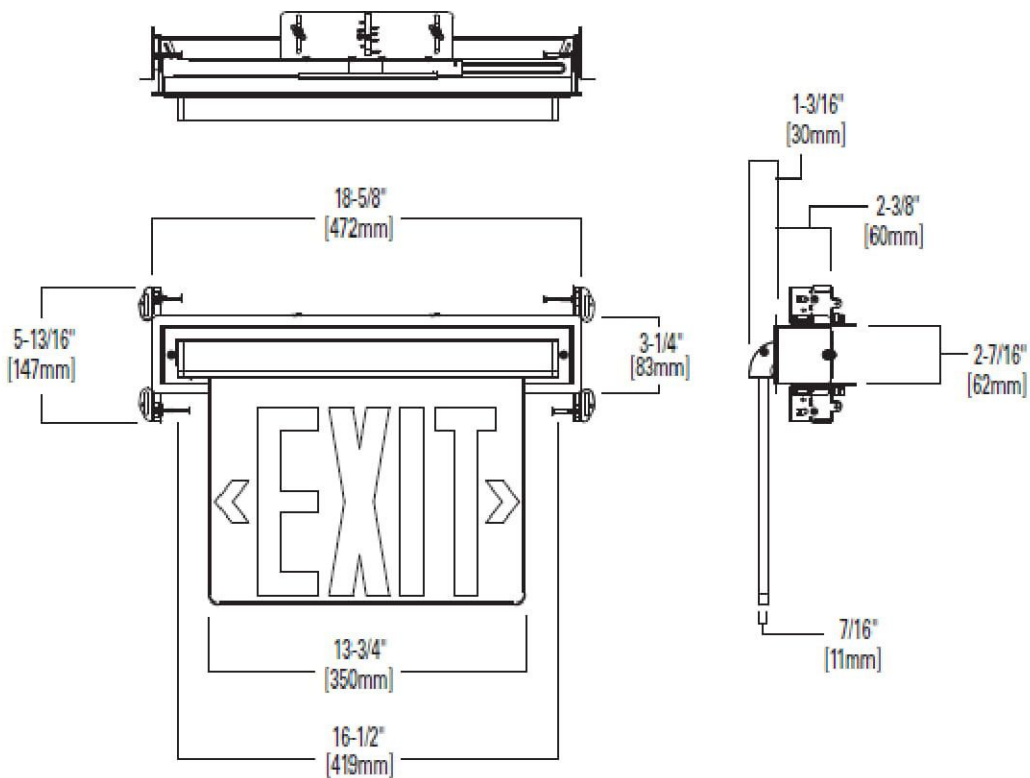

With Optional 6" Pendant Kit

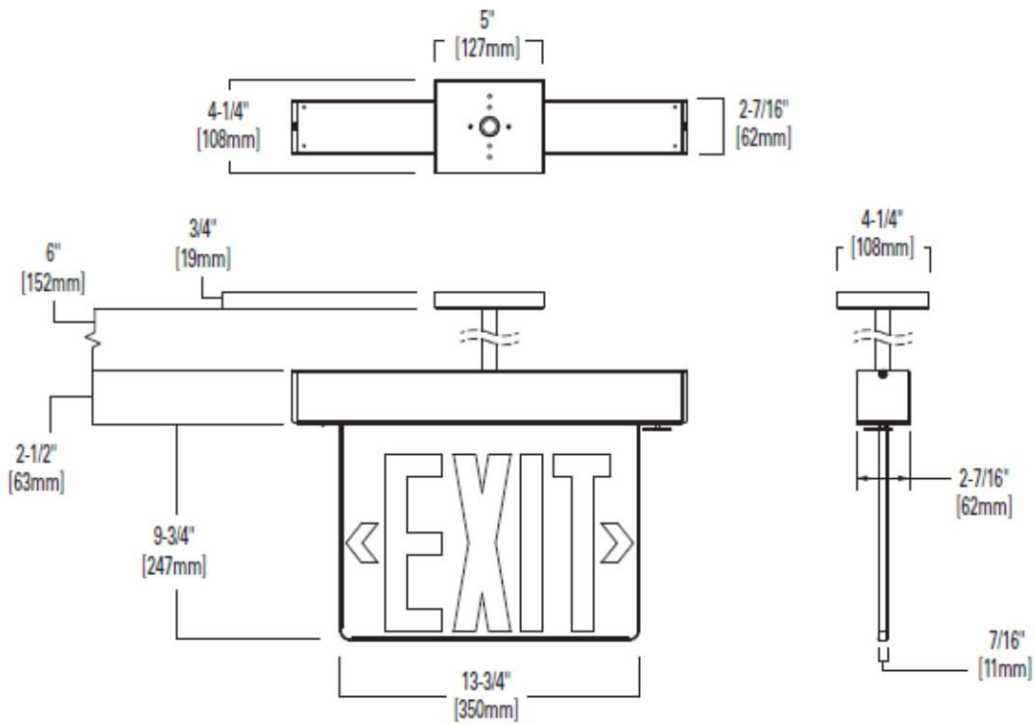

EXIT & EMERGENCY LIGHT

